

## Brico Pano

### Pine edge-glued panel

- Easy to work, rigid panel
- Natural surface, lightly sanded
- Optional finish: oil, wax, stain, varnish, paint

### Sizes available

Product codes	Sizes
836	11/16 x 8 x 36 in
848	11/16 x 8 x 48 in
1036	11/16 x 10 x 36 in
1048	11/16 x 10 x 48 in
1236	11/16 x 12 x 36 in
1248	11/16 x 12 x 48 in
1272	11/16 x 12 x 72 in
1296	11/16 x 12 x 96 in
1636	11/16 x 16 x 36 in
1648	11/16 x 16 x 48 in
1672	11/16 x 16 x 72 in
1696	11/16 x 16 x 96 in
2036	11/16 x 20 x 36 in
2048	11/16 x 20 x 48 in
2072	11/16 x 20 x 72 in
2096	11/16 x 20 x 96 in
2436	11/16 x 24 x 36 in
2448	11/16 x 24 x 48 in
2472	11/16 x 24 x 72 in
2496	11/16 x 24 x 96 in
3060	1-1/4 x 30 x 60 in

## Blanket Chest

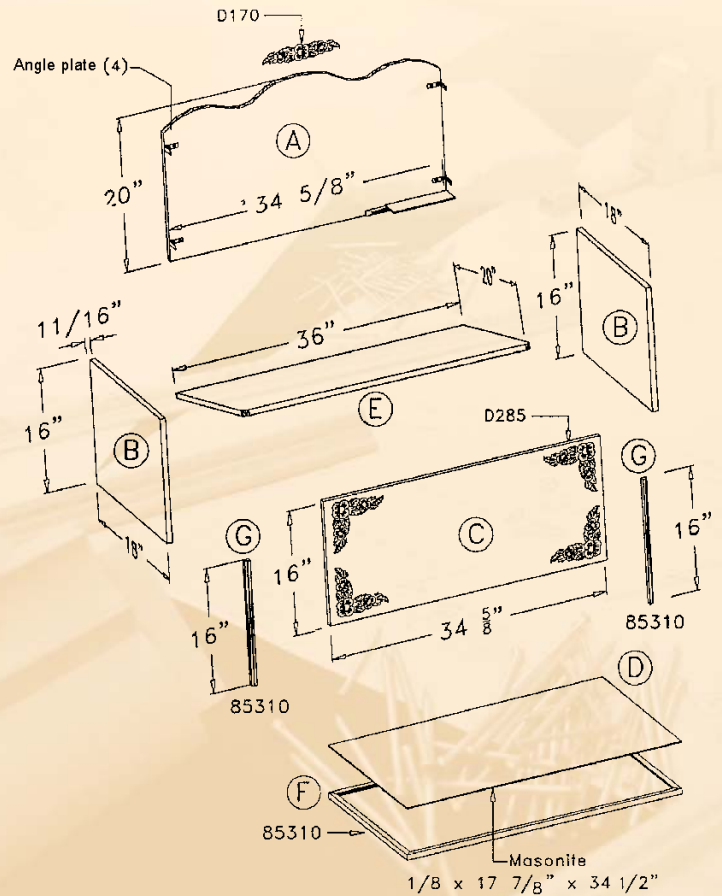

This brochure is designed to guide do-it-yourselfers. We cannot be held responsible for errors arising from its use. The best advice we can provide is that you should always check your measurements carefully.

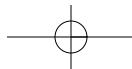

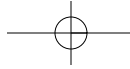

**• LIST OF MATERIALS**

**Finished sizes of materials**

**• (1) BRICO-PANO 72 X 20 in.**

A Back (1) 20 x 34-5/8 in.

E Top (1) 20 x 36 in.

**• (2) BRICO-PANO 36 X 16 in.**

B Sides (2) 16 x 18 in.

C Front (1) 16 x 34-5/8 in.

**• MASONITE 1/8 X 17-7/8 X 34-5/8 in.**

D Bottom (1) 1/8 x 17-7/8 x 34-1/2 in.

**• (2) QUARTER ROUND 1 1/16 in. X 1 1/16 in. #85310**

F Bottom Supports (2) 34-1/2 in. Quarter round  
(both ends cut at 45°)

(2) 17-7/8 in. Quarter round  
(both ends cut at 45°)

G Corners (4) 16 in. Quarter round

**• (1) ARABESQUE D170**

**• (4) ARABESQUES D285**

**• (8) ANGLE PLATES**

**• (1) 32 in. PIANO HINGE**

**• SCREWS No. 6 x 5/8 in. (square bit)**

**• SCREWS No. 8 x 5/8 in. (square bit)**

**• FINISHING NAILS (1 in. and 1-1/2 in.)**

**• #150 SANDPAPER**

**• COVER SUPPORT (Hardware)**

**• DECORATIVE CLASP (Hardware)**

**Required Tools**

- Hammer
- Scroll Saw (*Hand or Power*) or Saber Saw
- No. 6 and No. 8 Screwdrivers (*square bits*)
- Optional finish (*sealant, stain, paint, etc.*)

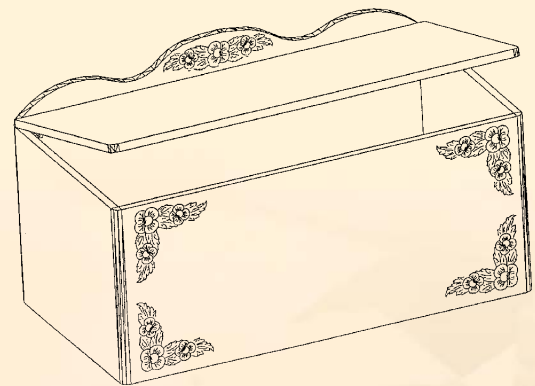

**Instructions**

- 1 Glue and nail the arabesque (*using with 1 in. nails*) to the top and centre of the 20 in. x 34 5/8 in. back panel as shown in the following diagram. Draw the shape of the back panel on a piece of cardboard, starting with the centre curve above the arabesque, and cut it out. Trace the shape on the back panel and cut it out using a scroll saw (*hand or power*).
- 2 Screw the angle plates onto the back and the front using No.8 x 5/8 in. long screws as shown on the diagram.

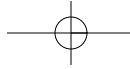
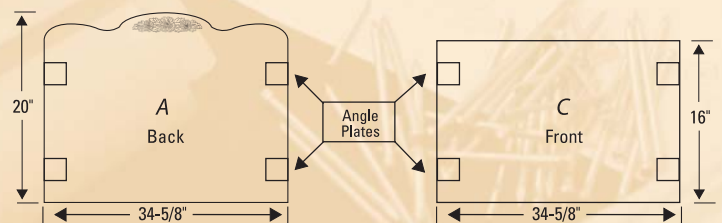

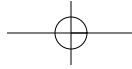

**Brico Pano**

**Brico Pano**

- 3 Join parts A, B and C corner to corner (*the empty spaces in the corners will be filled using quarter rounds (parts G).*) Make sure the corners are square.

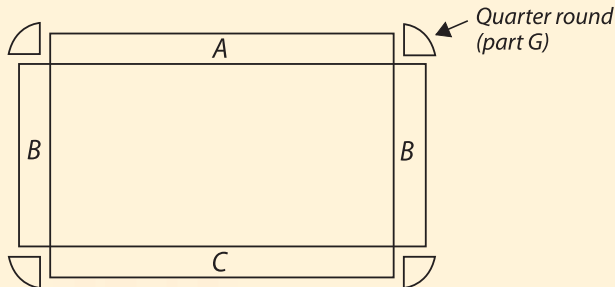

- 4 Put the quarter rounds (*parts G*) in place; glue, and nail them in using 1-1/2 in. finishing nails.
- 5 Nail the quarter rounds (*parts F*) inside the chest to support the masonite bottom.
- 6 Glue and nail the arabesques to the front (*part C*).
- 7 Put the top (*part E*) in place. Insert the hinge and mark with a pencil. Fasten the hinge using No. 6 x 5/8 in. long screws.
- 8 Fasten the lid support inside the chest and the clasp according to the manufacturer's instructions.

**Tips**

Scented blocks (*cedar or other*) may be placed inside the chest; the wood will absorb the scent.

*For finishing instructions, see the Tips and Finishing section.*

**Storage Bench for Entrance**

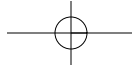
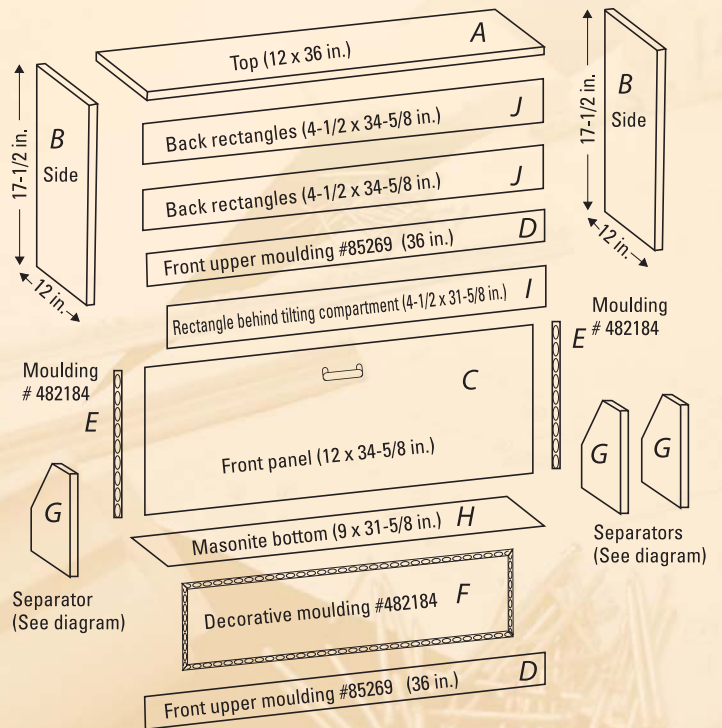

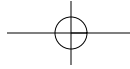

**• LIST OF MATERIALS**

**Finished sizes of materials**

**• (3) BRICO-PANO (12 x 36 in.)**

- A Top (1) 12 x 36 in.
- B Sides (2) 12 x 17-1/2 in.
- C Front panel (1) 12 x 34-5/8 in.

**• (1) CASING #85269**

- D Moulding #85269 (2) 36 in. long

**• (2) DECORATIVE MOULDING #482184**

- E Moulding #482184 (2) 12 in.
- F Moulding #482184 (2) 7 in. (both ends cut at 45°)
- (2) 29 in. (both ends cut at 45°)

**• (1) BRICO-PANO (10 x 36 in.)**

- G Separators (3) 9 x 9 in. (see diagram)

**• MASONITE 9 X 31-5/8 in.**

- H Masonite bottom (1) 9 x 31-5/8 in.

**• (2) PINE RECTANGLES (4-1/2 in.) #81447**

- I Rectangle #81447 (1) 4-1/2 x 31-5/8 in.
- J Rectangle #81447 (2) 4-1/2 x 34 5/8 in.

**• HANDLE**

- (2) SCREWS No. 8 (2 in. long)
- (2) SCREWS No. 6 (1 in. long)
- FINISHING NAILS 1 in. and 1-1/2 in.
- SMALL CHAIN 10 in.

**Instructions**

**1** Fasten the tilting compartment at the back of the front panel (*part C*); glue and nail (*using 1-1/2 in. nails*).

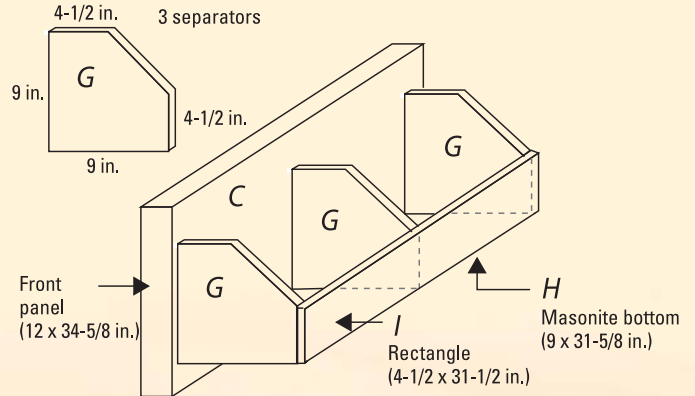

**2** Fasten the sides (*parts B*) to the top (*part A*); glue and nail (*using 1-1/2 in. nails*).

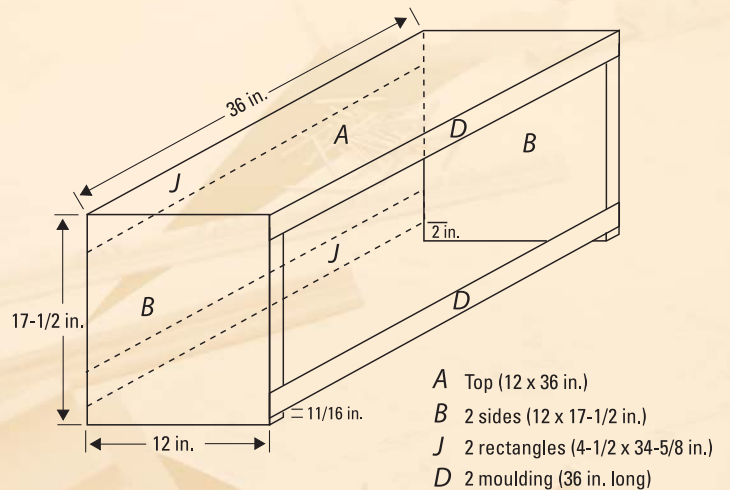

**3** Nail parts J at the back (*inside both sides B and top A*), one at the top and one at the bottom, leaving a 2 in. clearance from the ground. Fasten parts D in front, making sure the upper part is flush with the top and leaving an 11/16 in. clearance from the ground.

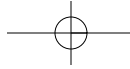

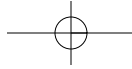

**Brico Pano**

**Brico Pano**

## Corner Cupboard

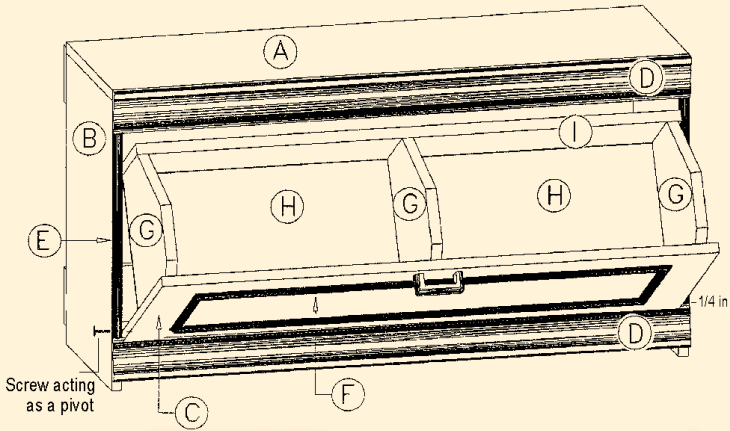

- 4** Set the front panel in place (*tilting compartment on the inside*). Make sure it is flush with the front, leaving a 1/4 in. gap between parts D and C. Mark the height of the bottom of the tilting compartment at the back in order to fasten a small piece of scrap wood about 1 in. x 4 in. to block the tilting compartment so that it remains flush with the sides. Pre-drill the sides and the tilting compartment using a 1/8 in. bit. Fasten with No. 8 x 2 in. long screws (*acting as a pivot*). Decorate the front panel (*part C*); glue and nail parts F in place to form a decorative panel moulding. Glue and nail parts E in place. To block the tilting compartment at the front, fasten the small chain using No. 6 x 1/2 in. long screws (*one end to part G, the other to part B*).



Cutting of the shelves out of a 16 in. x 48 in. Brico-Pano B

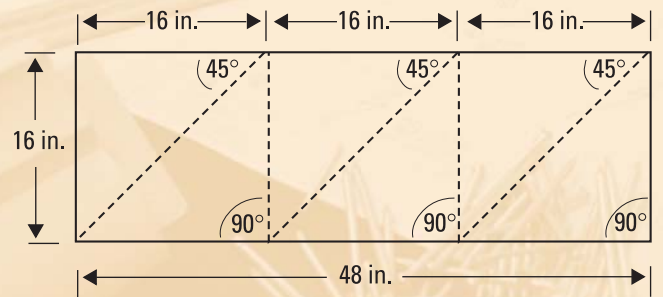
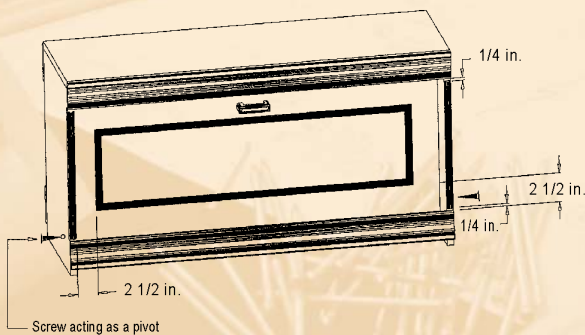

For finishing instructions, see the *Tips and Finishing* section.

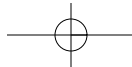



**• LIST OF MATERIALS**

**Finished sizes of materials**

**• (2) BRICO-PANO (16 x 72 in.)**

A Sides (2) 16 x 72 in.

**• (1) BRICO-PANO (16 x 48 in.)**

B Shelves (5) 22-1/2 x 16 x 16 in.  
(see cutting drawings)

**• (2) DECORATIVE MOULDINGS #85325**

C Mouldings # 85325 (2) Measure while installing

**• (1) QUARTER ROUND #85320 (1 1/16 x 1 1/16 in.)**

D Back support (1) 72 in. long

**• (1) CROWN MOULDING #85370**

E Cornice (1) Measure while installing

**• (1) FRAMING #85269**

F Base moulding (1) Measure while installing

**• (1) SURFACE MOULDING #85400**

G Moulding # 85400 (3) 22-1/2 in. long

**• FINISHING NAILS (1-1/2 in. and 2 in.)**

**• WOOD ADHESIVE**

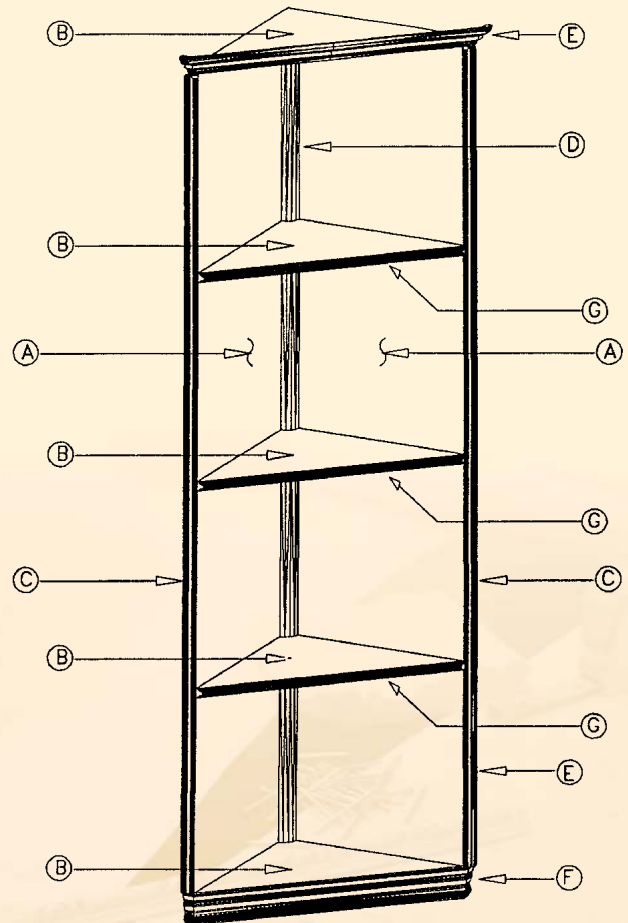

**Instructions**

**1** Assemble parts A and D as per diagram.  
Glue and nail (1-1/2 in. nails).

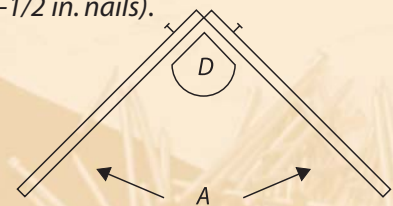

**2** Notch the tip of the shelves to lodge the quarter round.

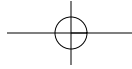

Shelf notched to lodge quarter round

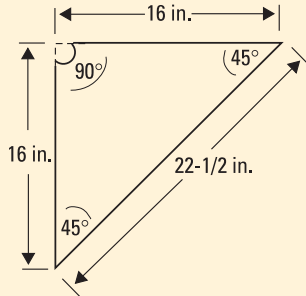

- 3 Put the uppermost shelf in place. Glue and nail (2 in. nails).
- 4 Put the lowermost shelf in place, 2 11/16 in. from the ground. Divide the distance remaining between the last 3 shelves equally or according to your needs.

- 5 Framing #85269 (F) acts as a base under the lowermost shelf. Measure the case front and the two sides. Cut the parts. Glue and nail (1-1/2 in. nails).

*Note: Line up part F with the top of the lowermost shelf. This will leave an 11/16 in. clearance from the ground.*

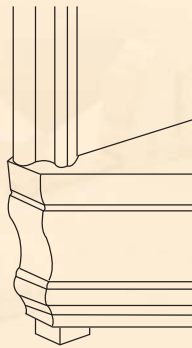

- 6 Glue and nail parts G (mouldings #85400) on the front of the shelves (1-1/2 in. nails).
- 7 Measure the location of parts C (#85325) from top to bottom inside the base and the cornice. Cut, glue and nail (1-1/2 in. nails).
- 8 To install the crown moulding #85370 (part E), measure the case front and pre-cut the crown moulding at 30° angles. Glue and nail (1-1/2 in. nails). Repeat on the other sides.

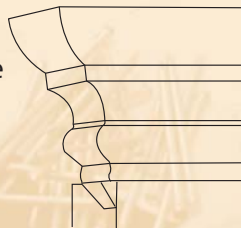

For finishing instructions, see the Tips and Finishing section.

## Tips and Finishing

Whether your finish choice be stain, paint, or faux finish, the basic precautions are most important if you are to get a quality finish that will enhance your work.

### Basic steps

- Sand the piece of furniture carefully, taking care to remove all defects.
- Take care not to leave excess glue at the joints (glue does not take stain).
- Dust the piece of furniture.
- Having completed these steps, try to avoid handling the piece of furniture: grease released from the hands prevents finish penetration in the wood.

### The stain option

- Use an oil- or a latex-based stain. Using a semi-transparent stain lets the wood grain show through, providing a warm aspect.
- On demonstration pieces of furniture, we have successfully used a semi-transparent latex-based stain applied with a brush, then wiped.
- After drying (24 hours), sand lightly (steel wool #000 or sandpaper #240).
- Dust carefully before varnishing.

### The paint option

- Apply a primer.
- Seal the knots using a coat of shellac.
- Sand to remove the wood grain lifted by the paint (steel wool #000 or sandpaper #240).
- Apply the finish layers according to the manufacturer's instructions.

*Let your imagination run free and you will be proud to have a unique piece of furniture that will blend with your surroundings.*

